

Projekt:
21.18 Neubau PP Unterholz Gemeinde Wangen a. A.
Projektadresse: Unterholz 29, 3380 Wangen an der Aare

provisorische Ausführung 31.1 Mst. 1:100, 1:20, 1:50

Gez. 11.08.2021 / th
Format: Gr.: 126 / 60
Stand: 07.04.2022 / fm

Bauherrschaft: Einwohnergemeinde Wangen a. A., Städtli 4 / Postfach 228, 3380 Wangen an der Aare, 032 631 50 78 / 079 614 16 07, lorenz.schmid@wangen-a.ch

Grundigentümer: Einwohnergemeinde Wangen a. A., Städtli 4 / Postfach 228, 3380 Wangen an der Aare, 032 631 50 78 / 079 614 16 07, lorenz.schmid@wangen-a.ch

Architekt: Müller + Partner dipl. Architekten HTL/STV AG, Eichenweg 16, 4900 Langenthal, p.arni@mueller-partner-ag.ch

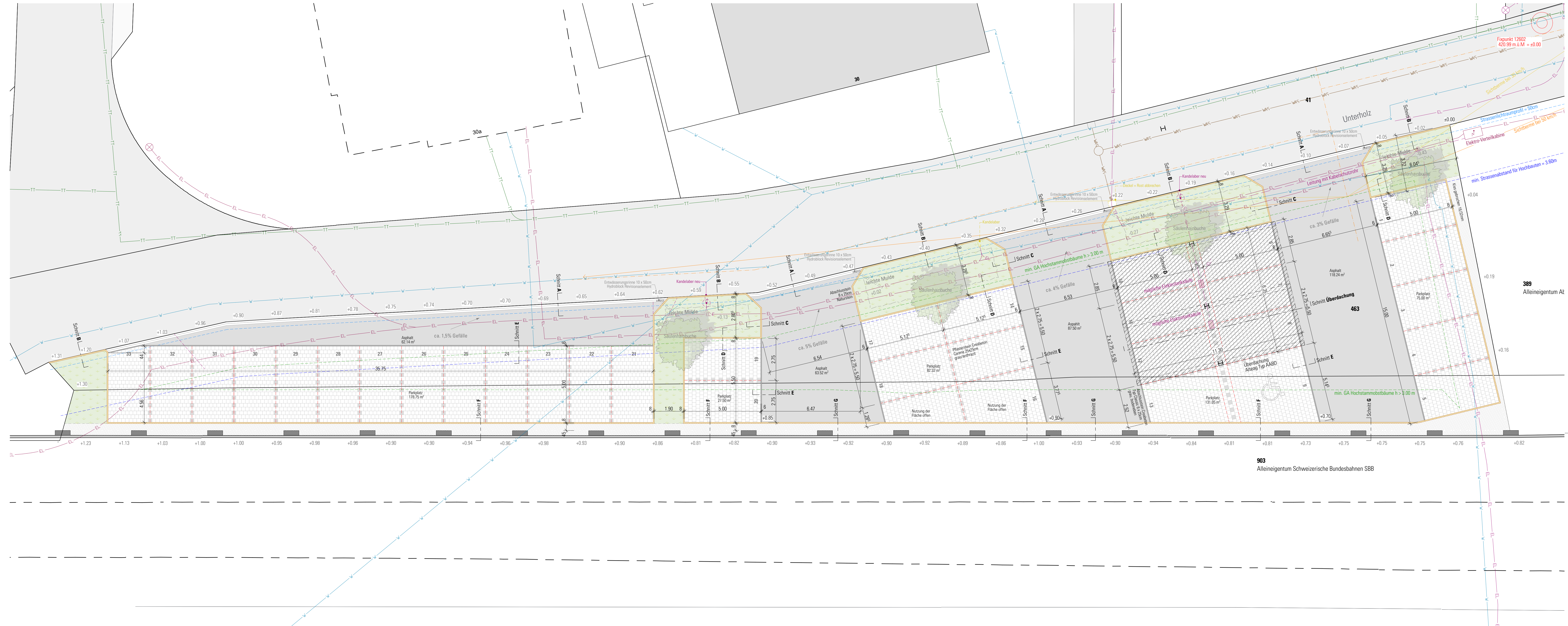
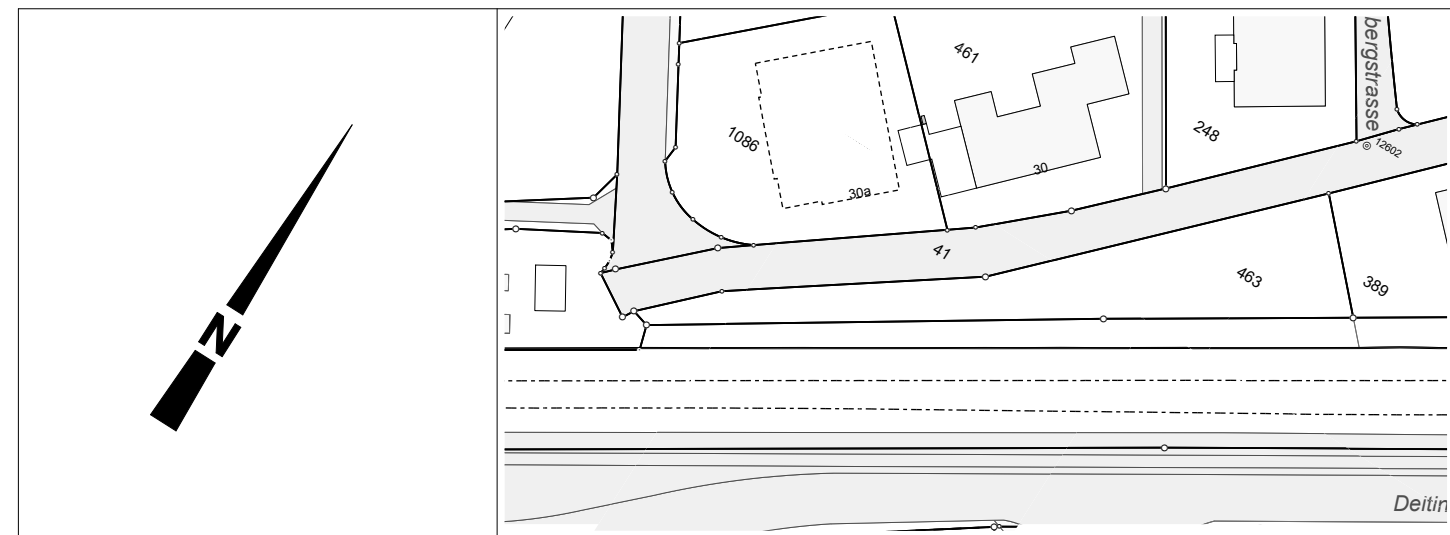

Grundriss 1:100

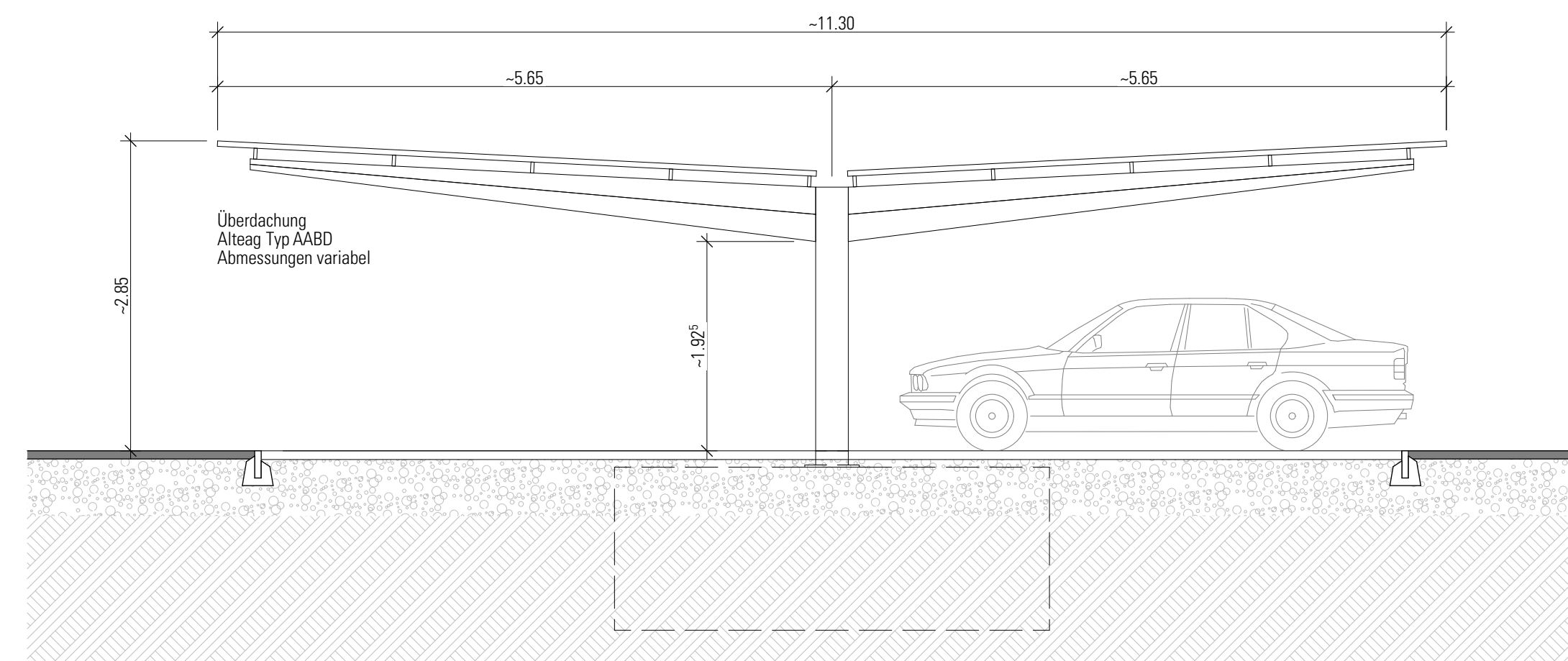

Schnitt Überdachung 1:50

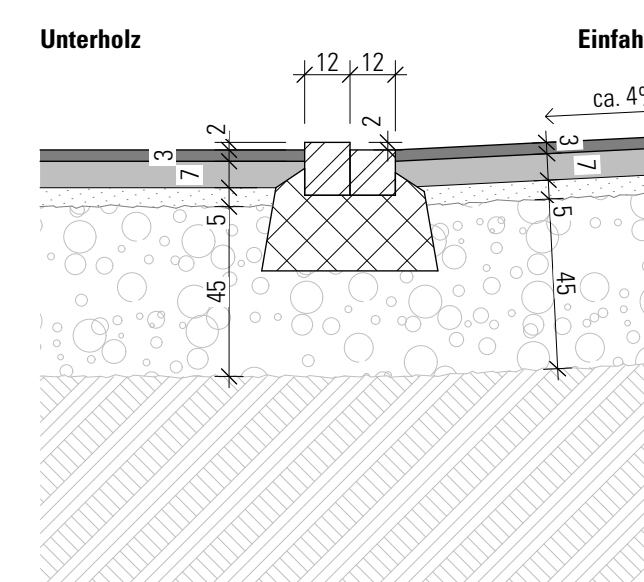

Schnitt A 1:20

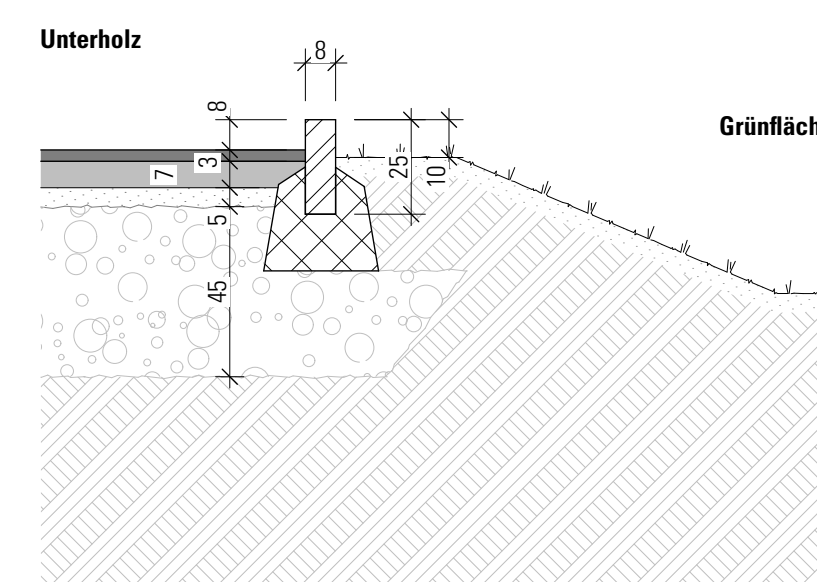

Schnitt B 1:20

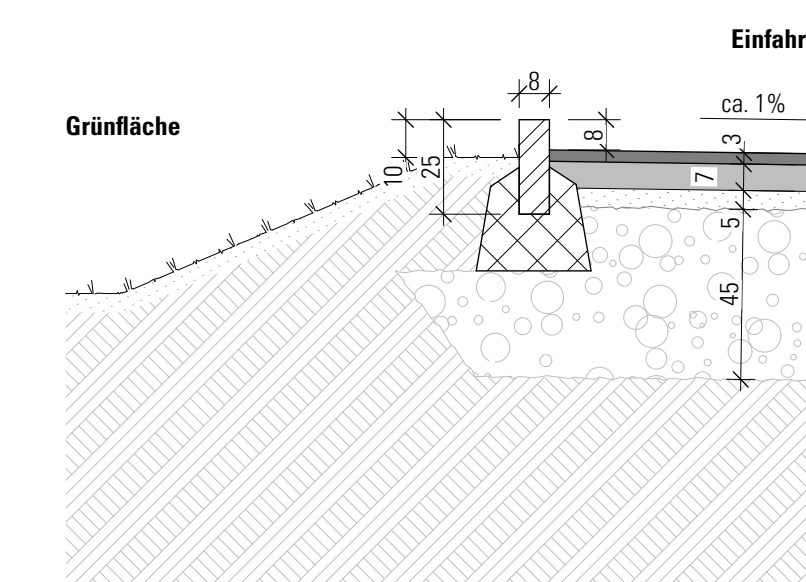

Schnitt C 1:20

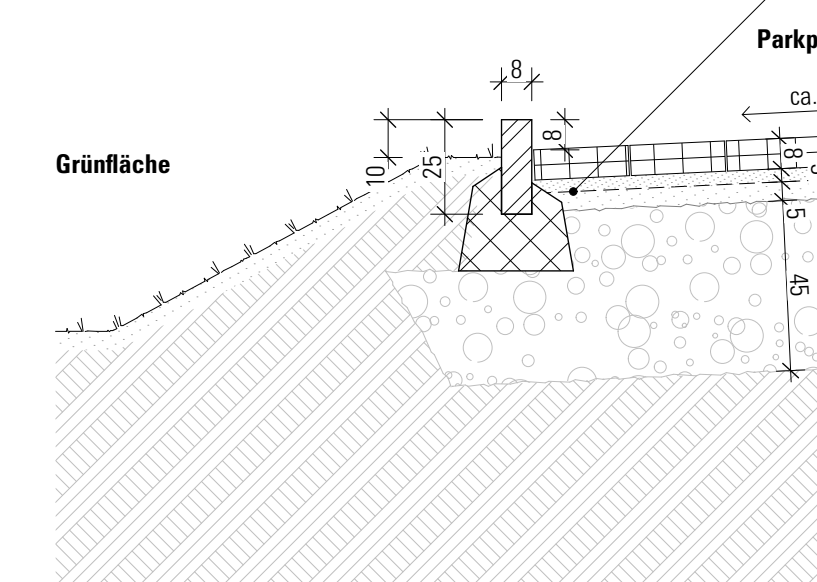

Schnitt D 1:20

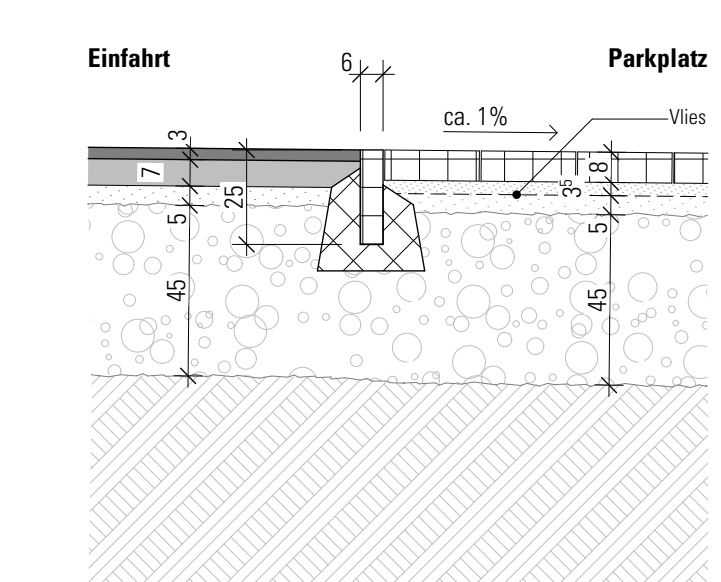

Schnitt E 1:20

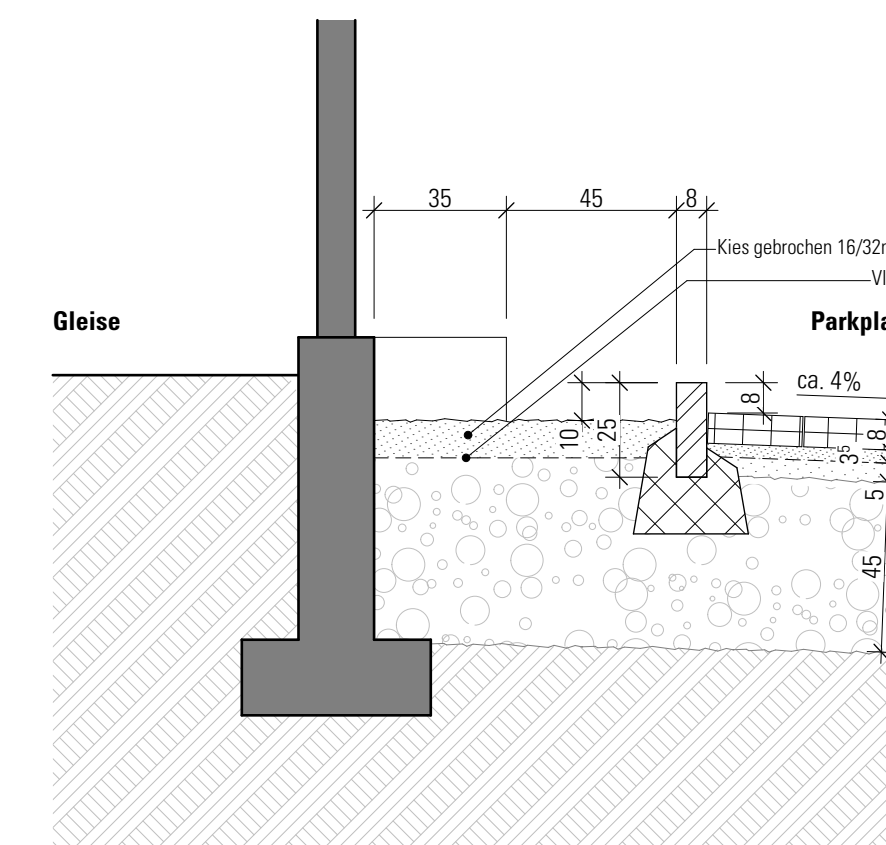

Schnitt F 1:20

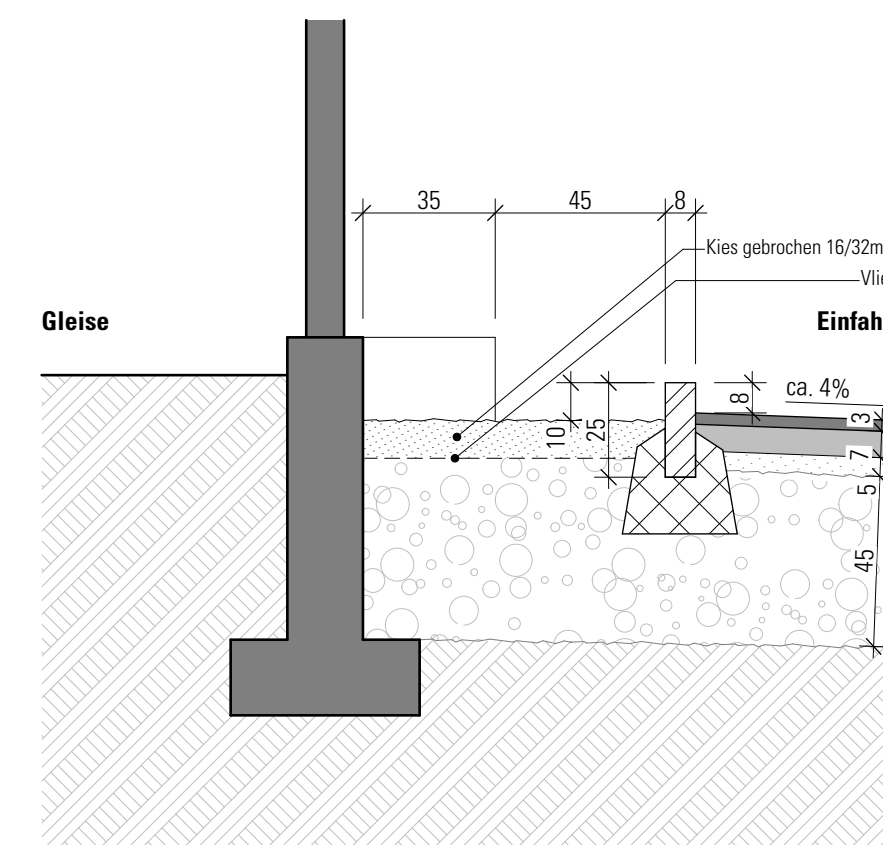

Schnitt G 1:20